



Herzlich Willkommen bei der
Georg Schrepfer GmbH
in Nürnberg



Georg Schrepfer GmbH

35 Mitarbeiter

Umsatz > 5 Mio. Euro

DIN ISO 9001 2015

DIN ISO 14001 2015



Seit mehr als 90 Jahren entwickelt und realisiert
GEORG SCHREPFER in Nürnberg
maßgeschneiderte Verpackungslösungen für den sicheren
weltweiten Transport von Industriegütern.



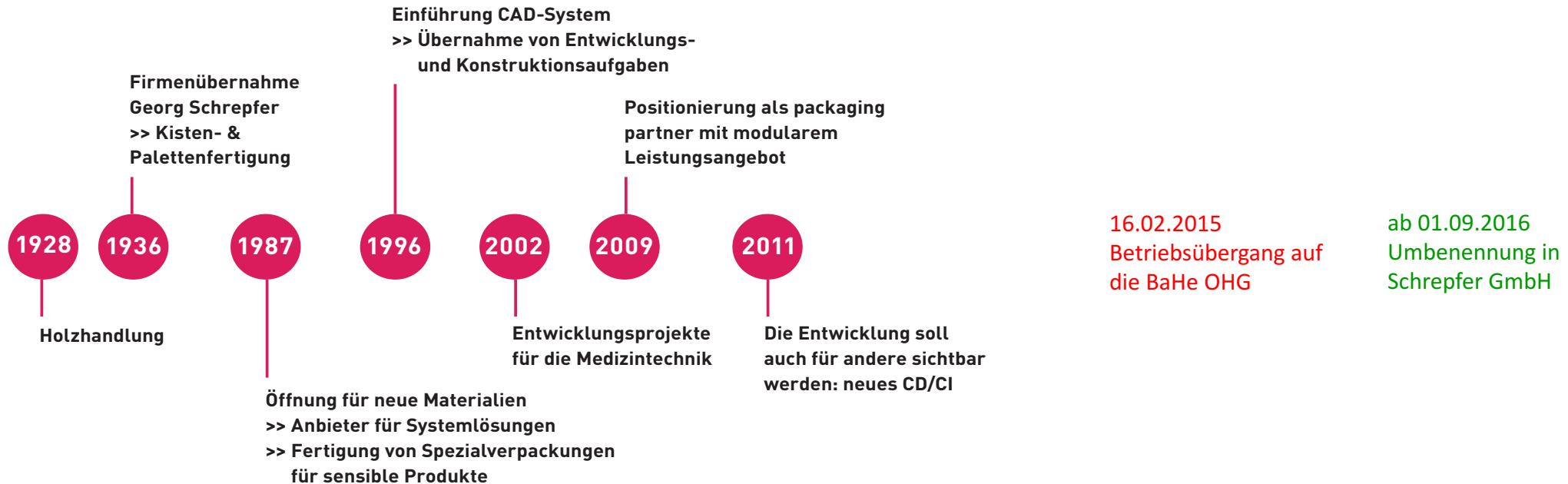

Geschäftsführende Gesellschafter: Martin Henselmann und Thomas Bach



Unsere Kernkompetenzen

Herstellung von Transportverpackungen
aus Holz und anderen Werkstoffen

Entwicklung und Konstruktion von Transportverpackungen,
Pendelverpackungen und Serviceverpackungen

Verpackungsdienstleistungen

Herstellung von CNC gefrästen Teilen aus Holz



seit 2/2018 CNC 5-Achs-Bearbeitungszentrum





Transportverpackungen für die Medizinindustrie, Flightcases, Transportkoffer

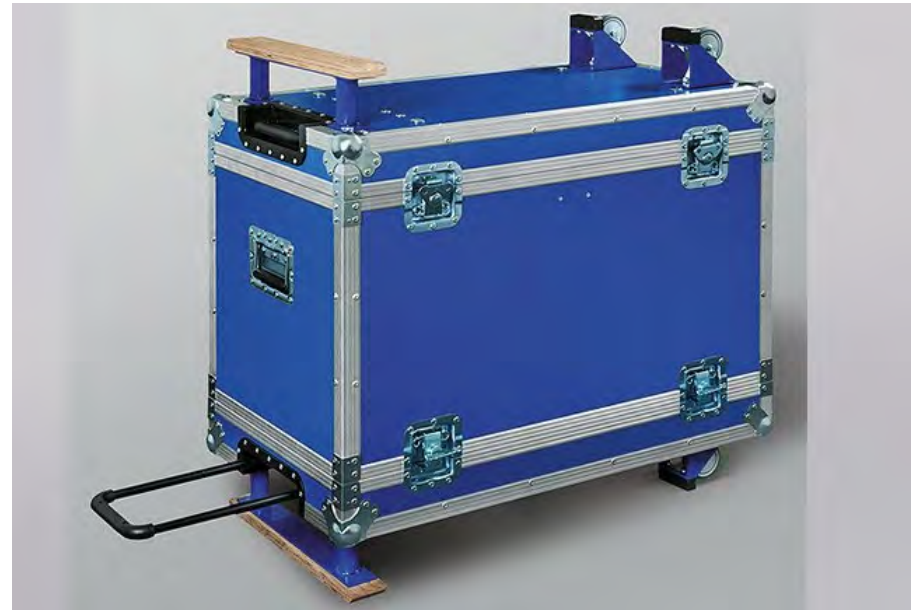
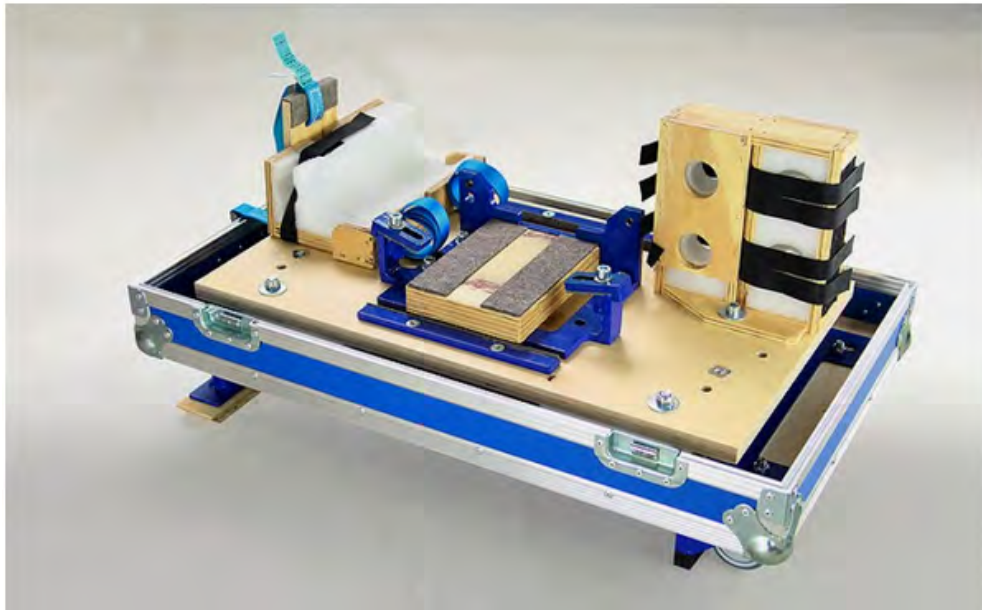

Entwicklung, Konstruktion, Prototypenbau, Serienfertigung

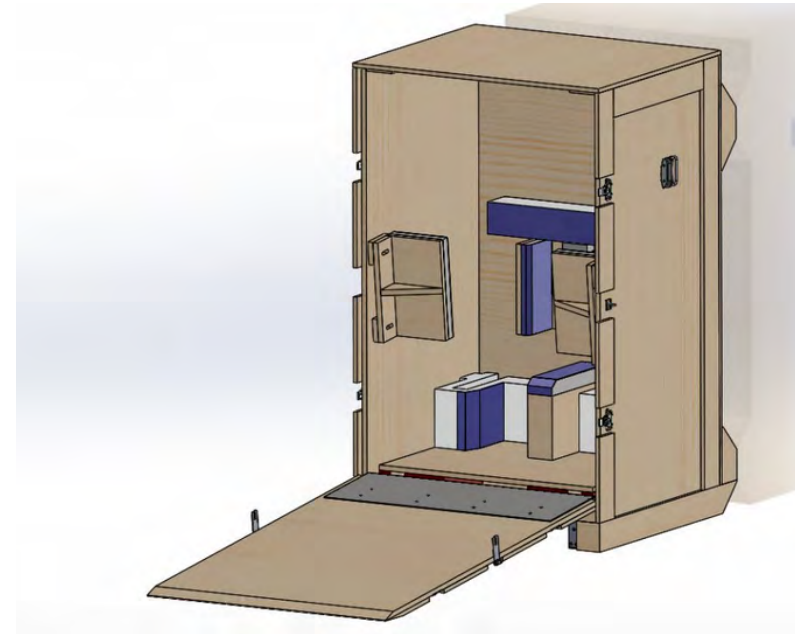
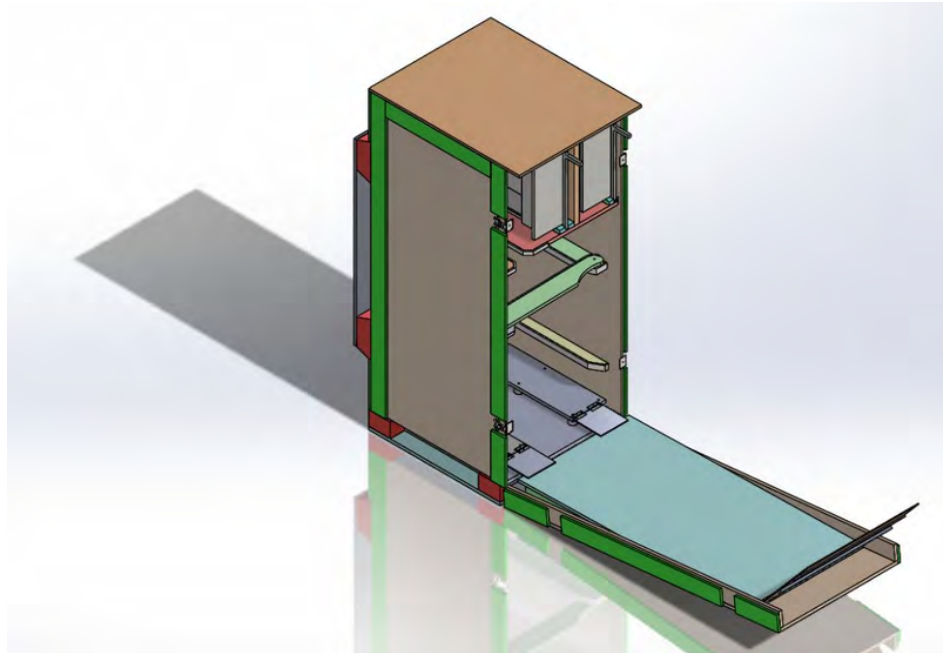



Exportverpacken für Straße, Luft & See



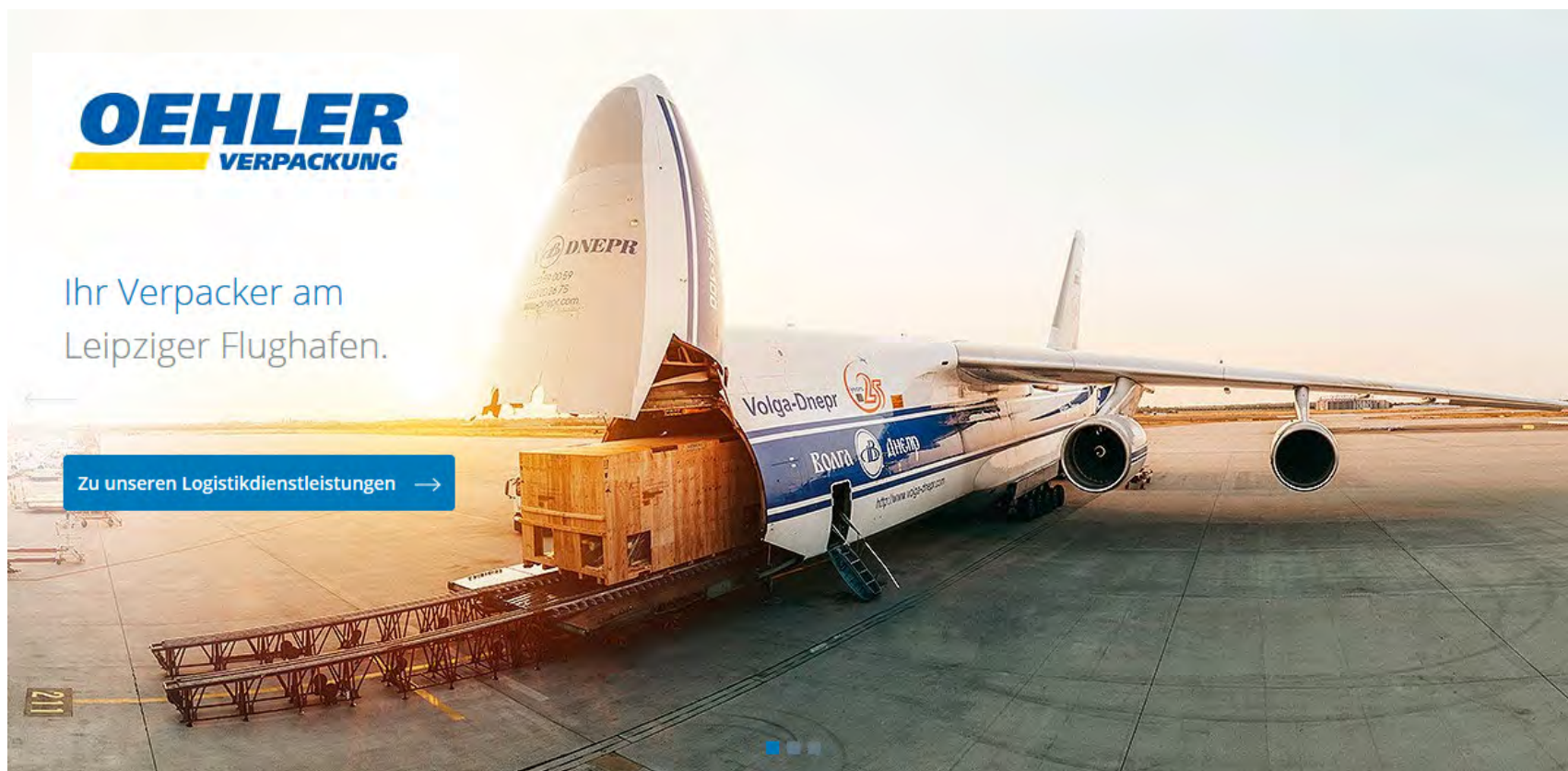



Oehler Verpackung GmbH

70 Mitarbeiter

Umsatz 5 Mio. Euro

DIN ISO 9001 2015

DIN ISO 14001 2015



Mehr als 100 Jahre Tradition

Vormals Andreas Oehler e.K.
seit 1.1.2017 Oehler Verpackung GmbH

Geschäftsführende Gesellschafter:
Martin Henselmann und Thomas Bach





3000 qm Hallenfläche

Schwergut auch über 100 Tonnen

2 x 20 t Krananlagen

Gefahrgut

Reglementierter Beauftragter Luftfracht

Einlagerungen, Transportdienstleistungen

Eigene Kisten- und Haubenproduktion





Vielen Dank für Ihre Aufmerksamkeit!

Haben Sie noch Fragen?





Entwicklung & Konstruktion für Transportverpackungen

OEHLER
VERPACKUNG



Wir packen das für Sie
GEORGSCHREPFER



Was bedeutet Entwicklung & Konstruktion für uns?

- Das Entwickeln einer speziellen Transportverpackung, welche unterschiedliche Voraussetzungen erfüllen muss
- Keine „Standardprodukte“
- Das Konstruieren der Verpackung mittels einer CAD-Software (SolidWorks)

Was sind die Kriterien?

- Empfindlichkeit des Produktes?
- Wie muss es gelagert werden?
- Was wird transportiert? Wohin?
- Vorgaben des Kunden
- Gewicht des Packgutes

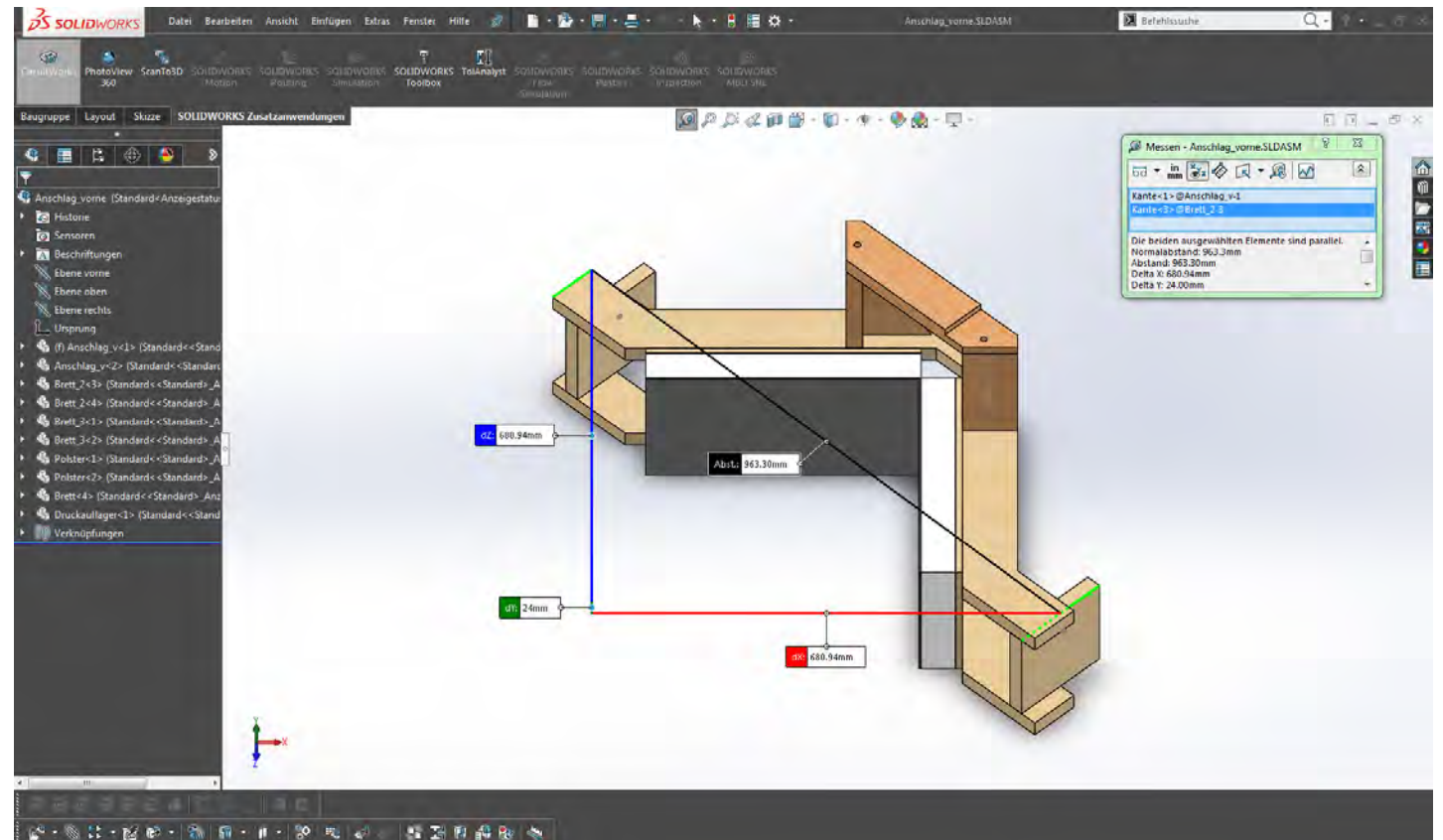

Der Prozess

- Absprache der Kriterien mit dem Kunden
- Erstes Konzept
- Materialauswahl treffen
- Erstellung von 3D-Modellen im CAD-Programm
- Konzeptvorstellung beim Kunden mit Richtpreisangebot
- Freigabe der Konstruktion und Abgabe eines genauen Angebotes
- Erstellung eines Prototypen
- Testphase beim Kunden
- Mögliche Zertifizierung der Transportverpackung (Tests)
- Freigabe durch den Kunden für die Serienfertigung



Der Kunde kann auch nur einzelne Bereiche des Prozesses beauftragen

Projekt 1: Fahrstativ – Röntgengerät zum weltweiten Transport

- Versand Weltweit
- LKW/Luft/See/Schiene
- Hohe Empfindlichkeit
- Vibrationstest
- Falltest
- Stapelbar
- Pendelverpackung
- Verschließbar

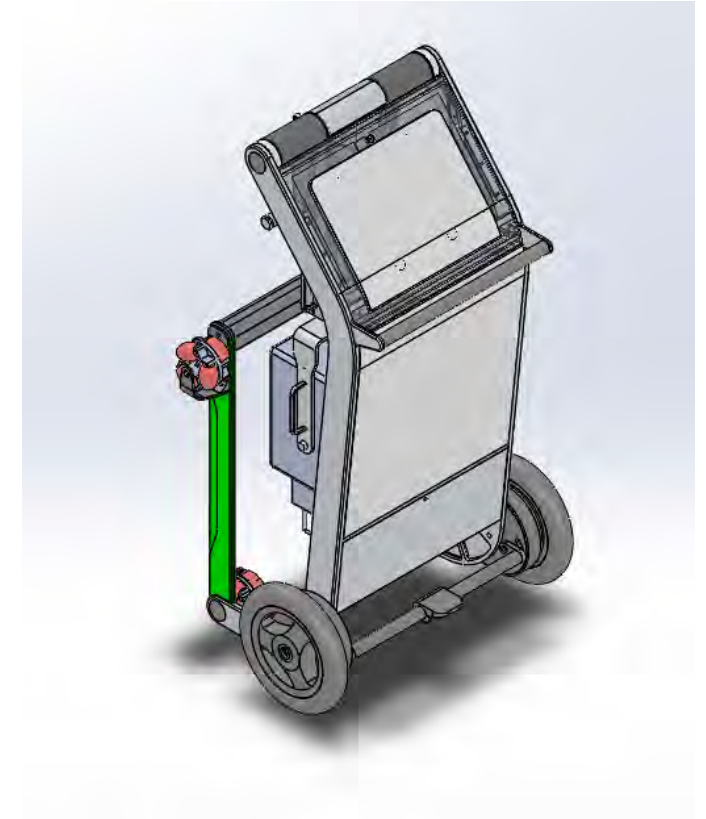
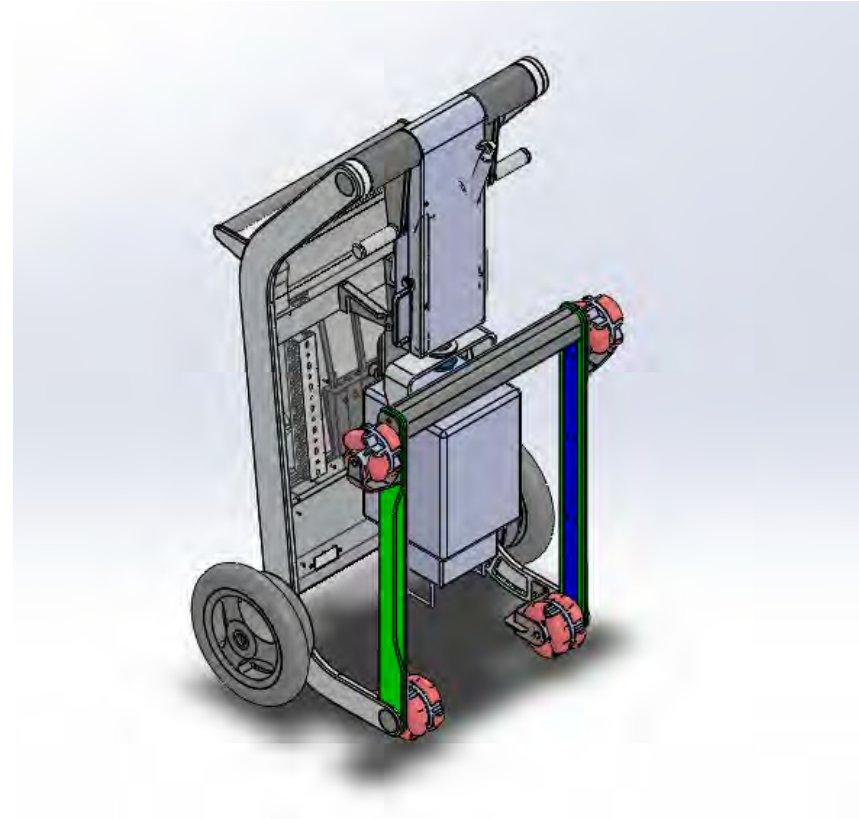

Projekt 1: Fahrstativ

- Multiplex
- Schaumstoffe für die Polsterung
- Filz um Abrieb zu verhindern
- Div. Beschläge und Schrauben
- Spanmaterial

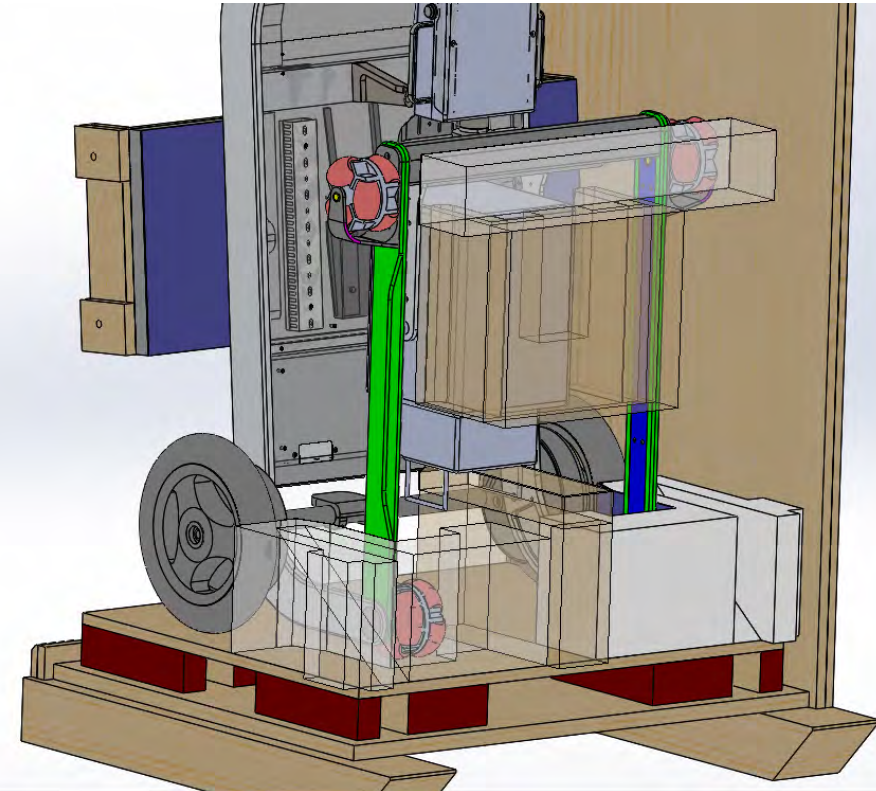
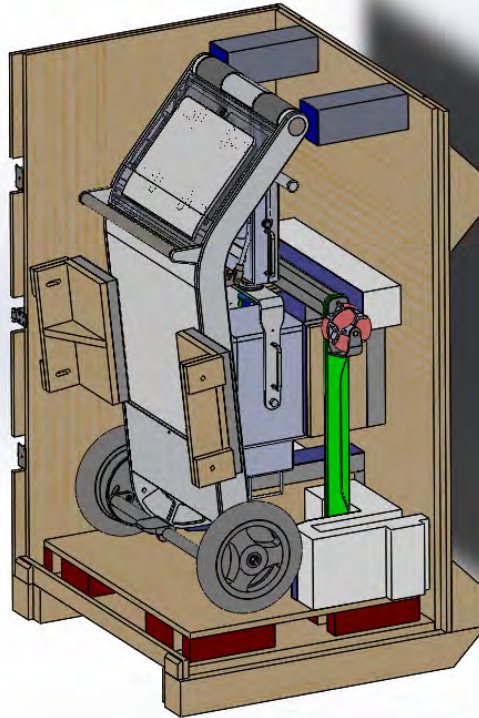

Projekt 2: Motoren

- Versand Deutschlandweit
- LKW
- 4-fach unterfahrbar
- „Gefache“
- Größe ca.: 1200 x 800 mm
- Stapelbar
- Pendelverpackung
- Einfaches Handling
- Anzahl!!!
- Kein Kunststoff/Wellpappe
- Umweltgedanke!!!

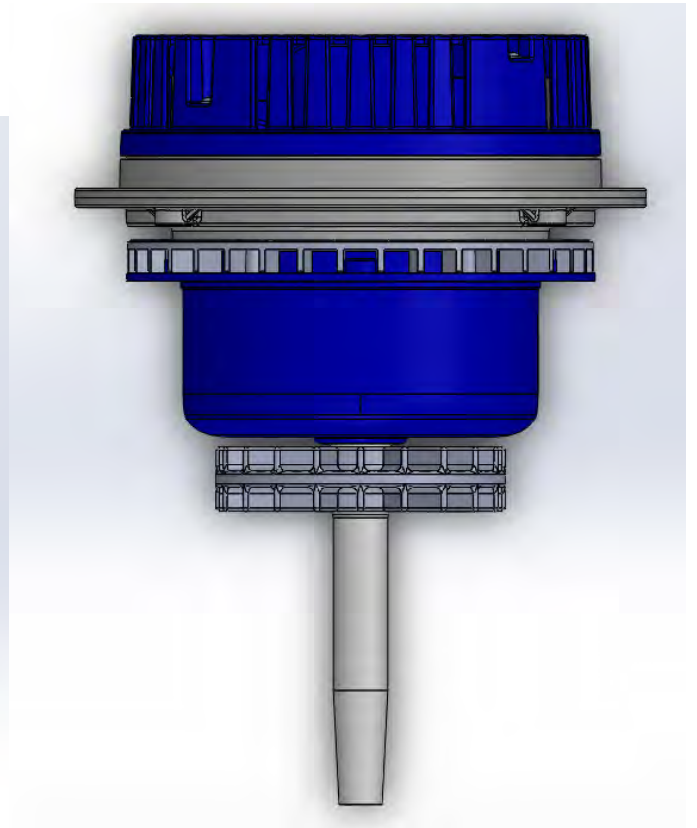
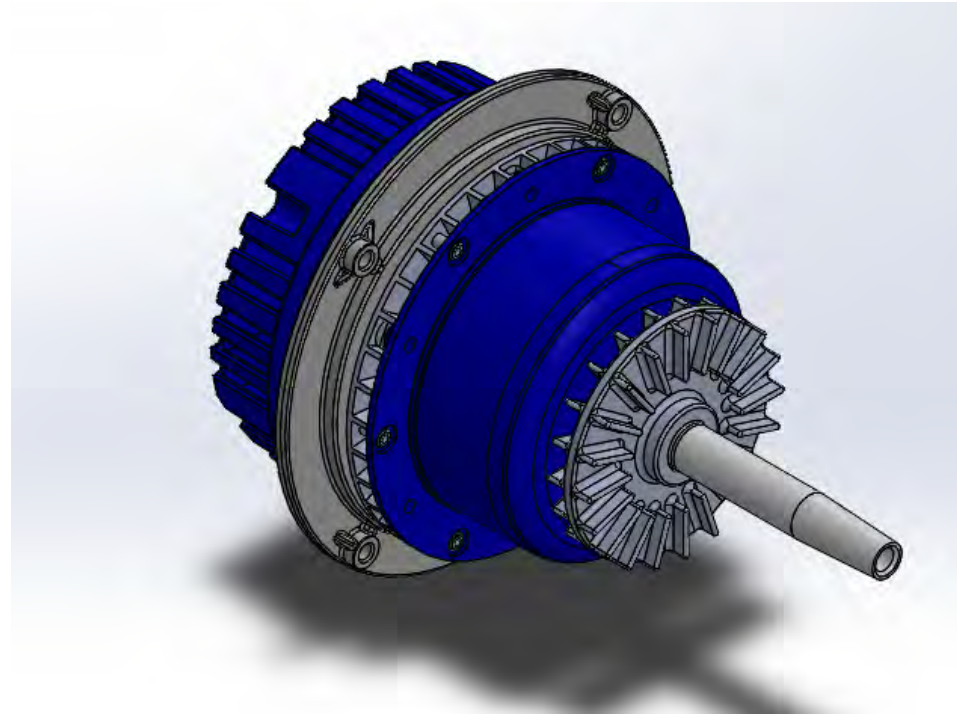

Projekt 2: Motoren

- SPH
- CNC-Bearbeitung
- 1 Satz = 5 Stück
- Anzahl Motoren: 100 Stück pro Satz
- Pendelverpackung
- Variabler Aufbau
- Austauschbare Teile

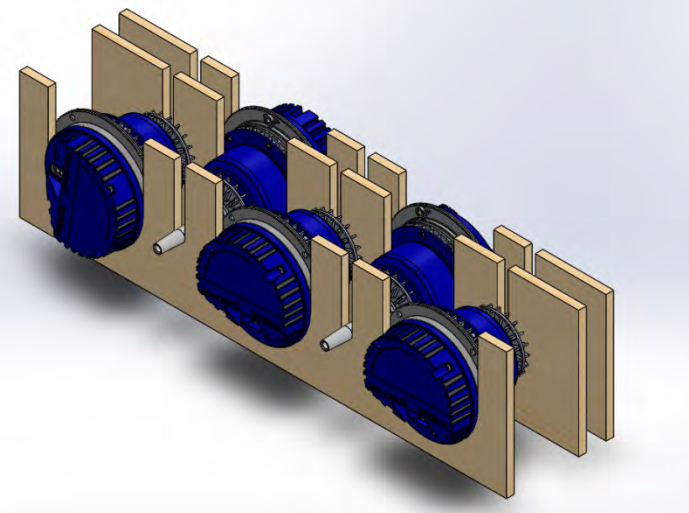
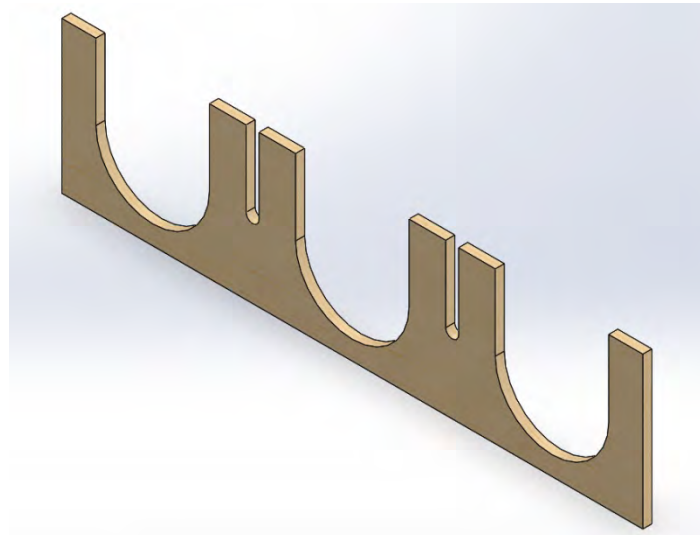
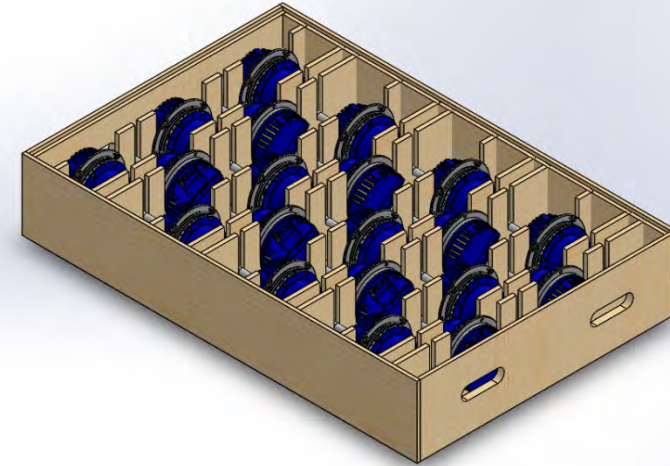

OEHLER
VERPACKUNG



Wir packen das für Sie
GEORG SCHREPFER

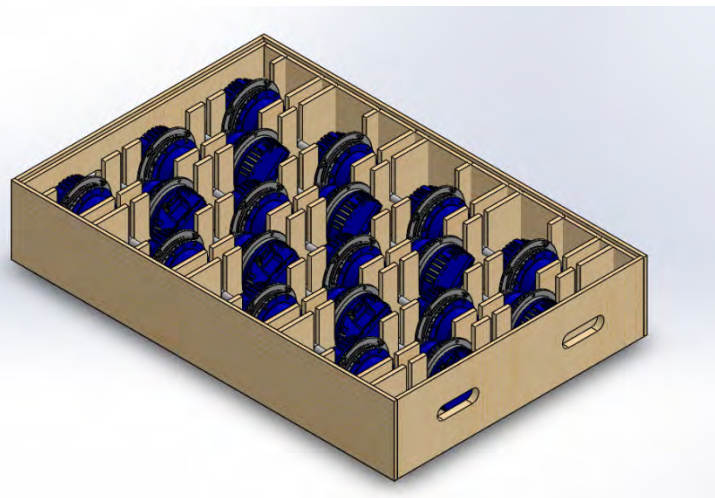
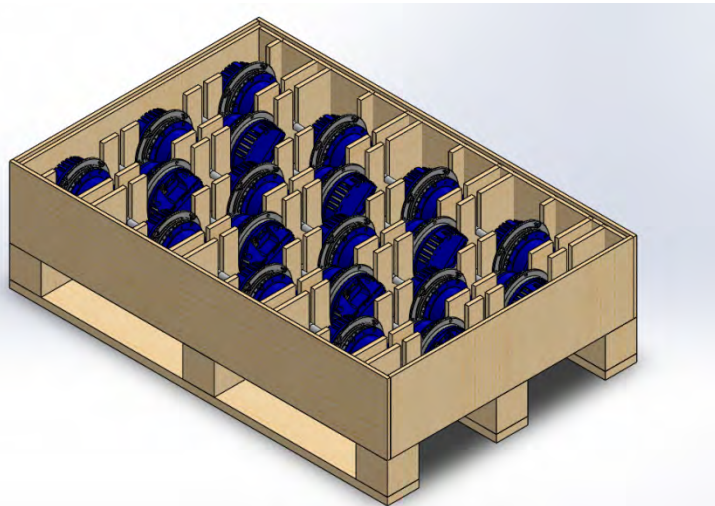



Zusammenfassung:

- Serienverpackungen
- Pendelverpackungen / Messekisten
- Einfaches Handling der Transportverpackungen für unseren und seinen Kunden
- Entwicklungs- und Konstruktionsdienstleistungen werden in Rechnung gestellt
- Erfolgsquote liegt bei ca. 65 %

OEHLER
VERPACKUNG



Wir packen das für Sie
GEORGSCHREPFER



Fragen





Vision Industrie 4.0

OEHLER
VERPACKUNG



Wir packen das für Sie
GEORGSCHREPFER



Vision Industrie 4.0 bei Georg Schrepfer / Oehler

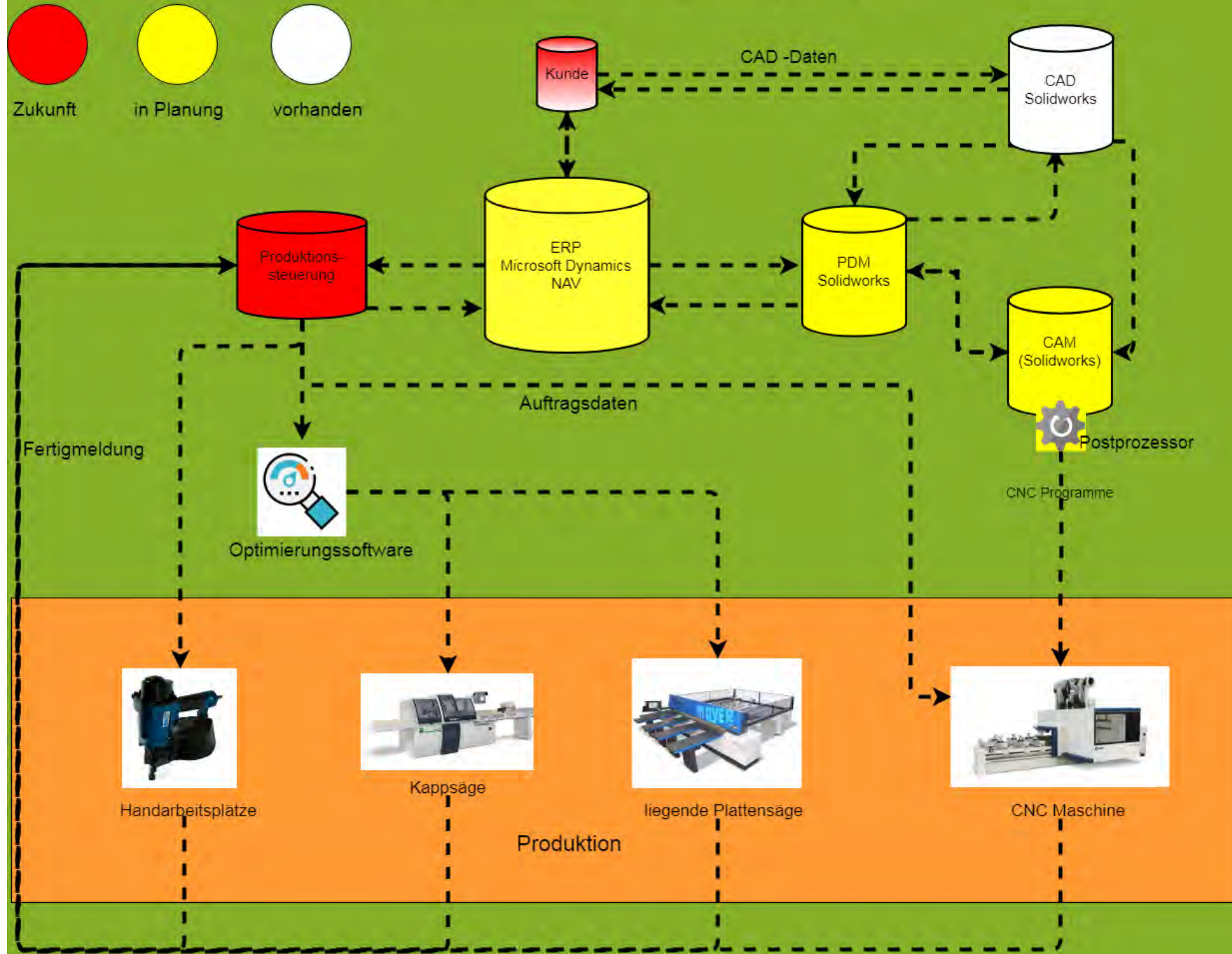



Fragen

Eigene Visionen

